

Learning to BOW on open strings	
Bowling signs	
▣	- Down Bow
∨	- Up Bow
,	- Lift Bow

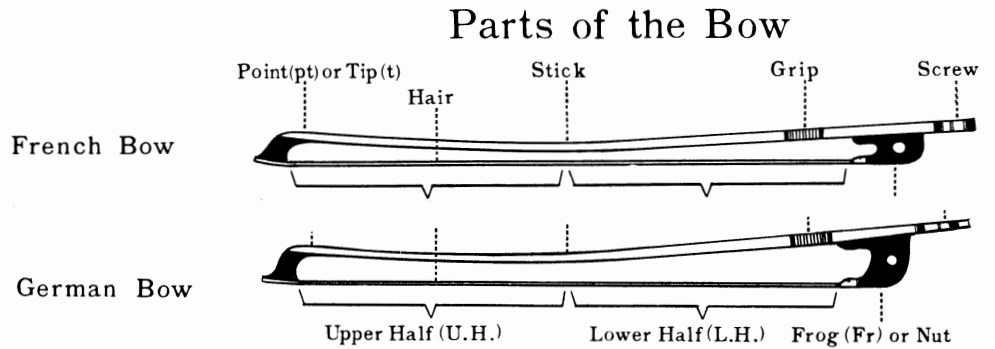

Play the following exercises using the various parts of the bow.

30

The D String	repeat sign	The A String	The G String
▣ ∨ ▣ ∨	▣ ∨ sign	▣ ∨ ▣ ∨	▣ ∨ ▣ ∨
D r D r D r D r	D r D r	A r A r A r A r	G r G r G r G r

BOWING OPEN STRINGS

31

32

33

34

35

36

37

lift bow

Play Ex. 1-6 using the bow.

NEW NOTES A-B-C#
on the A string

G
D
A

0 1 4 0

fingering

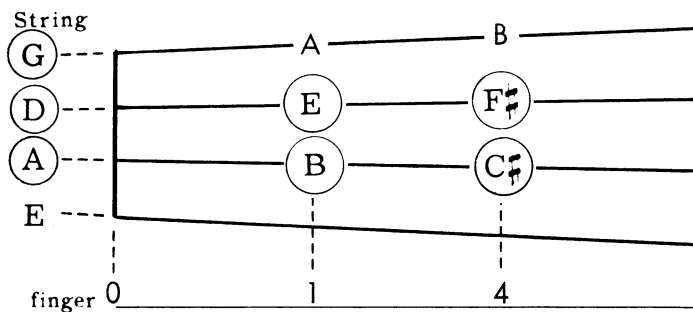

Count - Sing - Play (When crossing strings, keep fingers down)

58

0 0 0 0 1 1 4 4 4 4 0 0 0 0 0 0 1 1 4 4 4 4 0 0

0 0 0 0 4 4 1 1 1 1 0 0 0 0 0 0 4 4 1 1 1 1 0

59

0 0 4 4 0 4 1 1 0 0 1 0 0 0 4 4 0 4 0 0 4 4 0 0

MARCH ONWARD (Sing - Play)

60

(A)

SHORTNIN' BREAD (Sing - Play)

61

(A)

REUBEN AND RACHEL (Sing - Play)

62

Play Ex. 26-29 using the bow.

2nd finger
 Note F on D string
 Note C on G string

C D E F G A

G D A 2 0 1 2 0 1

B C

4 → 4
 slide finger
 along string

String
 G D A E

A B C

E F C

finger 0 1 2 4 4

Slide the finger along string

Sing - Play - Circle all F's

104

105

C MAJOR SCALE

F \sharp - 2nd finger on D string; C \flat - (high) 4th finger on G string. Slide finger along the string to place where tone sounds correct.

106

2 0 1 2 0 1 4 → 4 4 → 4
 slide finger

107

4 → 4
 slide finger

108

4 4 4 4 → 4
 slide finger

WORK AND PLAY

109

4 → 4 4 4 → 4
 slide finger

SUMMER DAY

110

WINKUM

111

3/4 TIME

3 - 3 beats per measure
4 - a quarter note receives 1 beat
Sing - Play

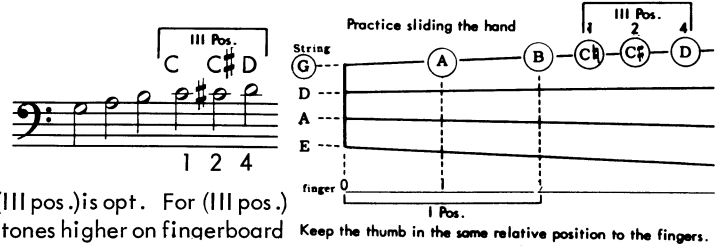

115

THE DOTTED HALF NOTE

A dot adds one half the value of the note. The half note receives two counts. The dot, half of this or one count. The two together receive three counts. (♩ = 1-2-3)

116

117

118

119

A FRENCH SONG

120

BETSY FROM PIKE

121

PIZZICATO WHILE HOLDING THE BOW

Extend the second finger away from the bow. Pluck the string with the second finger of the right hand.

The number (2) with the letter "p" under it means to pluck the string with the 2nd finger of right hand. Arco = use bow.

140 Pizz. arco Pizz. arco

141 Pizz. arco Pizz. arco Pizz.

142 Pizz. arco Pizz. arco

Keep the thumb in the same relative position to the fingers.

Practice sliding the hand

Review of III Position on the G string

III Pos. 1 2 4
C C# D

III Pos. 1 2 4

String G D A E

finger 0 1 4

I Pos.

144

Optional III Pos. 1 4 4 1

145

146

147

* Now you can play GRAND MARCH and GYPSY WEDDING MARCH in Müller-Rusch "Orchestra Performance #1"