

# SHIFTING TO THE SAME FINGER – CLASS 1 SHIFT (Ascending)

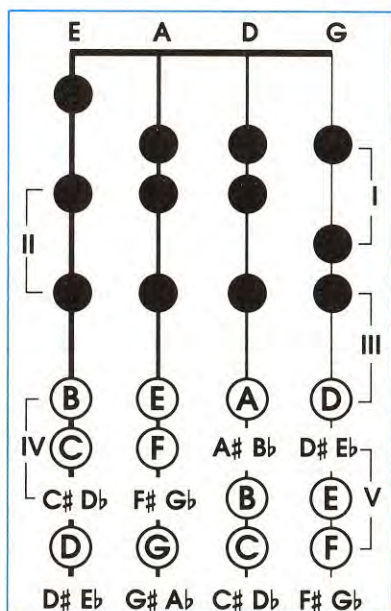

First (I) Position to Third (III) Position  
and  
First (I) Position to Fourth (IV) Position

## SHIFTING INSTRUCTIONS

1. Move your hand, thumb, fingers and forearm together.
2. Lead with your forearm in the direction of the shift.
3. Slightly release the pressure of the sliding finger during the shift.
4. Keep the sliding finger in contact with the string during the shift.
5. Keep your hand, thumb and forearm relaxed.
6. Slow down the bow speed and lighten the bow pressure during the shift.

## 93. SHIFTING TRAINER

Three staves of musical notation in bass clef, 4/4 time. Each staff starts with a circled letter (A, B, C) and shows ascending and descending shifts with fingerings (I, II, III, IV) and bowing marks.

## 94. MARINES' HYMN

Offenbach

Allegro

Two staves of musical notation in bass clef, 4/4 time. The first staff starts with a dynamic marking 'f'. The notation includes various fingerings and bowing marks.

★ This is the harmony part. Listen to the melody played by the violins and violas.

## 95. NIFTY SHIFTER

Anderson

Two staves of musical notation in bass clef, 4/4 time. The notation includes complex shifting patterns with fingerings and bowing marks.

★ Keep the sliding finger in contact with the string during the shift.